

CAD FILE:

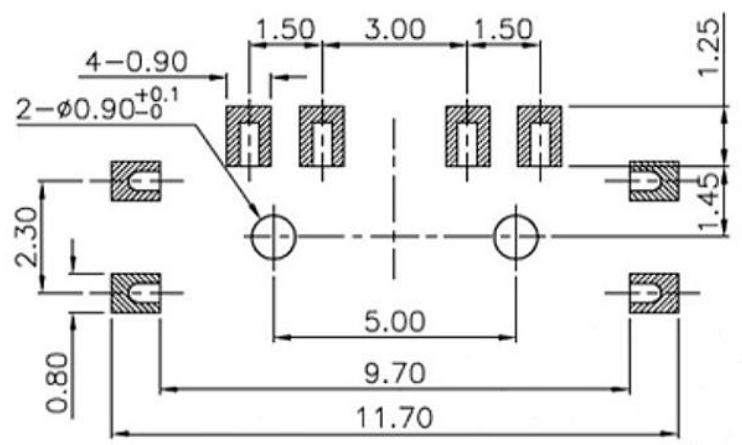

PCB Layout(Pattern side)

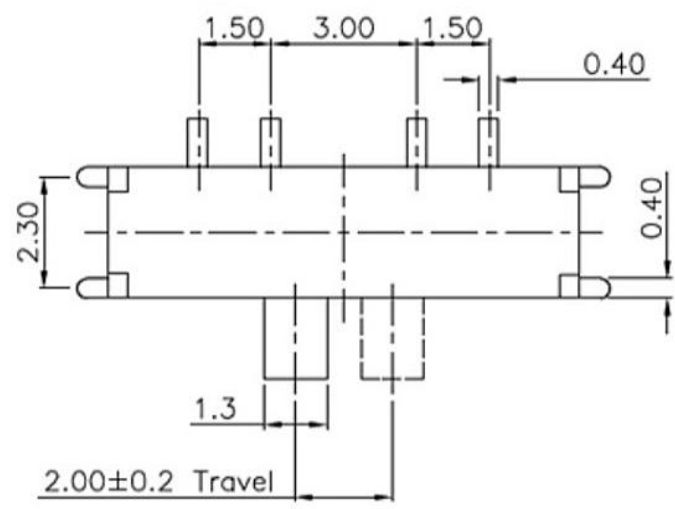
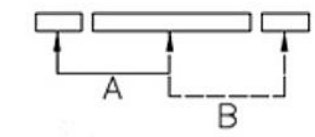
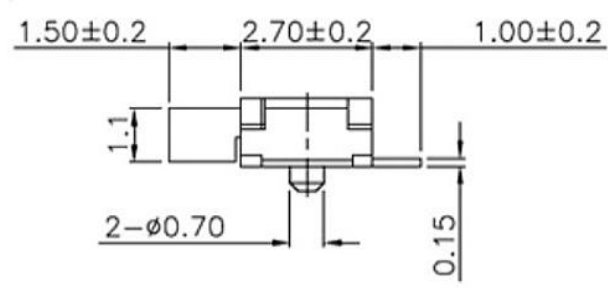
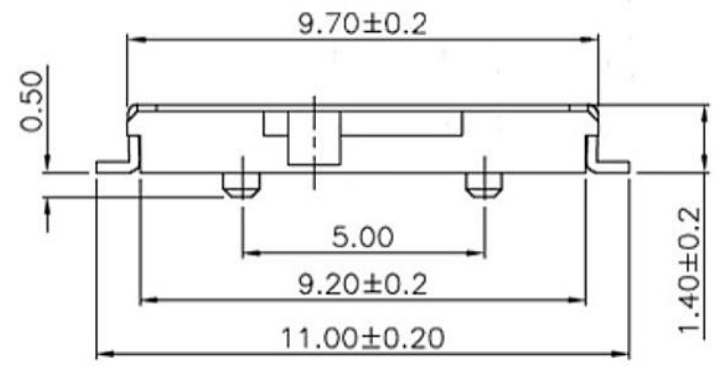

Circuit Diagram

注: "*"表示关键尺寸(6个)

NO.	PARTS	MATERIALS	Q'TY	FINISH	TOLERANCE							
8					UNLESS SPECIFIED							
7	STEEL BALL	STEEL	1	NATURAL	WITHIN		A	2012-10-26	初版			
6	SPRING	STEEL WIRE	1	NATURAL	OVER		ISSUE	DATE	DESCRIPTIONS OF REVISION			
5	CONTACT CLIP	PBS STRIP	2	Ag PLATED	TITLE : SLIDE SWITCH				UNIT : mm	DRWG NO.:		
4	TERMINAL	BRASS STRIP	8	Ag PLATED	MODEL:				SCALE: 3:1	DWN.	2012-10-26	
3	BASE	PHENOLIC RESIN	1	NATURAL	東莞市高迪電子有限公司 DONGGUAN GAODI ELECTRONICS CO., LTD.				CHK'D		2012-10-26	
2	FRAME	STEEL STRIP	1	Ni PLATED					APPD.			
1	KNOB	POM	1	BLACK								